

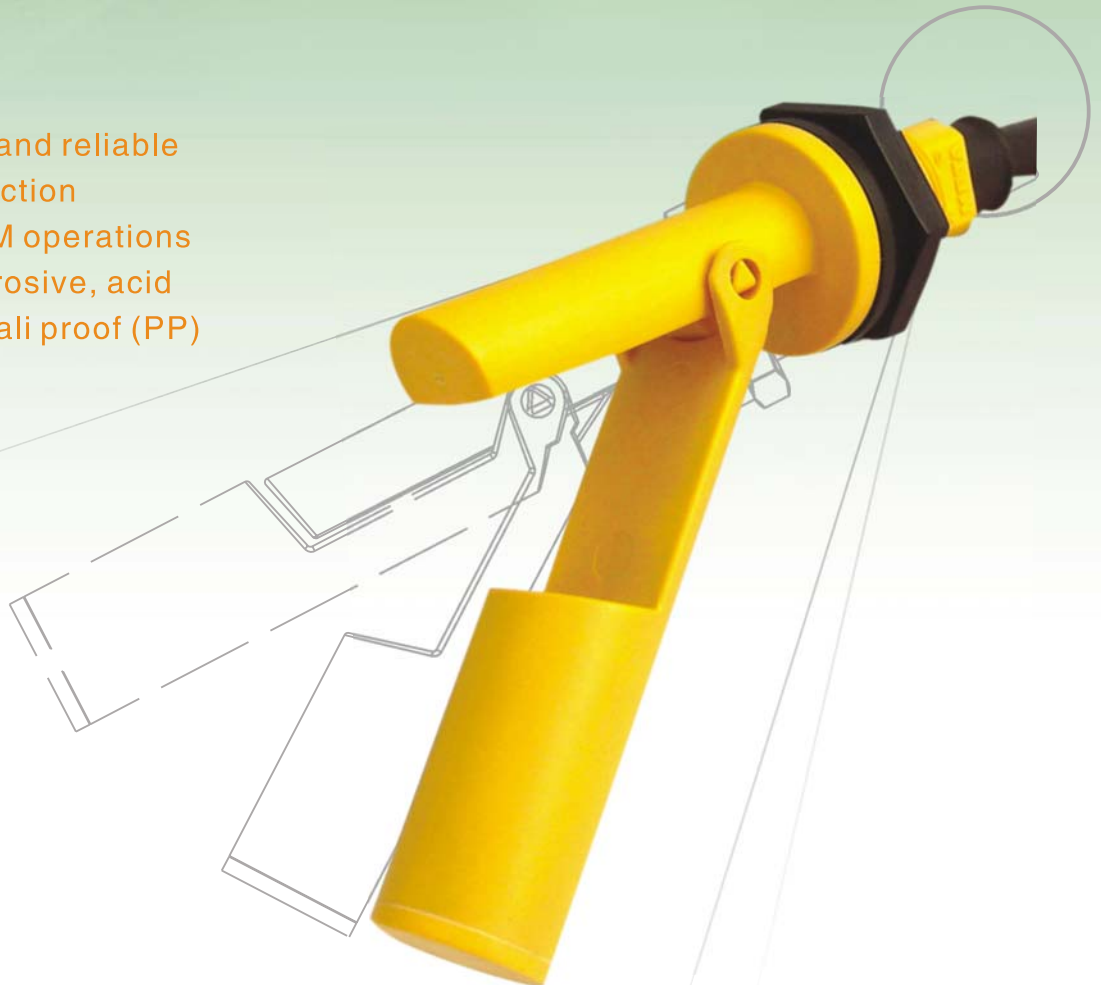

## 04 SERIES Float level switches

- Simple and reliable construction
- Up to 2M operations
- Anticorrosive, acid and alkali proof (PP)



## Float level switches

### Features

LS series is featured for concise structure, delicate design, durable operations, and perfect function. They are extensively installed in the fuel tanks, oil-pressure equipments, chemical and cooling vessels, and etc. Furthermore, they are mostly used to sense substance such as water, oil, and chemicals. There are three different materials of LS series available now for varied needs from customers.

### Dimensions

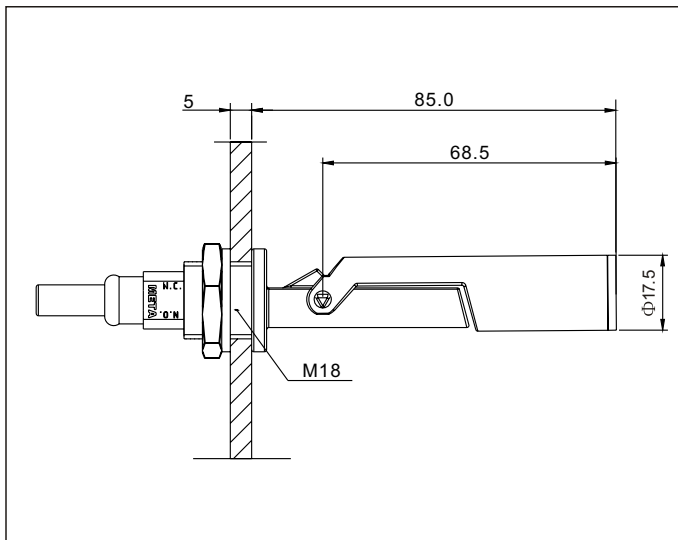

### Operating Principle

Set up a magnetic reed switch inside the hermetic plastic tube and then anchor the float which is hollow and magnetic in the position related to the magnetic reed switch inside the pole. Liquid makes the float up and down in the fixed range when the specific weight of float is smaller than that of liquid. Use the magnet inside the float which attracts the magnet reed switch to control the level of liquid. NC or NO is the state without any liquid poured.

### Connection

LS series is outputted by magnet reed, and the user can choose the status of NC or NO by the way of mounting. It can connect to the control system such as PLC, Relay, and etc.

Precision :  $\pm 3\text{mm}$  under water

Repetition:  $\pm 1\text{mm}$  under water

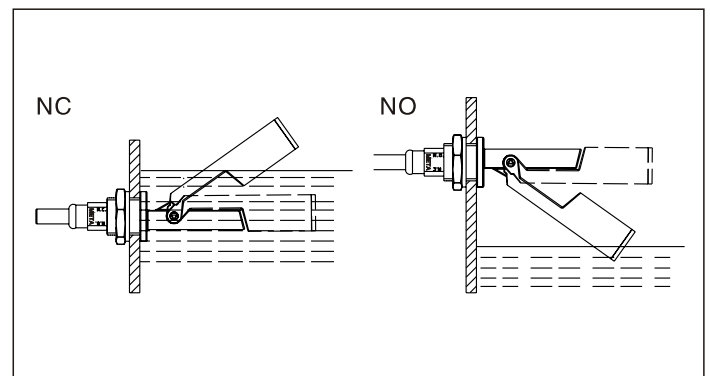

Order number	LS0001	LS0002	LS0003
Type	Standard	High temperature	Strong acid / alkali
Sensing medium		Liquid	
Electrical design		DC / AC	
Output		NO / NC	
Operating voltage		Max. 240V AC/DC	
Current rating		0.5A (240V AC/DC)	
Socket		M18 M18 thread	
Capacity		70W	
Sensing degree		$\pm 30^\circ$	
Storage humidity		20%~70%	
Operating humidity		20%~70%	
Operating temperature	-20°C~80°C	-20°C~120°C	-20°C~100°C
Ambient temperature	-20°C~80°C	-20°C~120°C	-20°C~100°C
Ambient pressure		10 bar	
Contact resistance		80 $\Omega$	
Housing material	PBT+30%GF	PA66+30%GF	PP+30%GF
Connection	1PVC 1m PVC cable	1PUR 1m PUR cable	1PUR 1m PUR cable
Protection classification		IP68	
Certification		CE、RoHS	

PP PH0~14

Notice: PP is allowed to be used under the conditions with PH 0~14.